

## CLAMP-ON PIPE SHOE

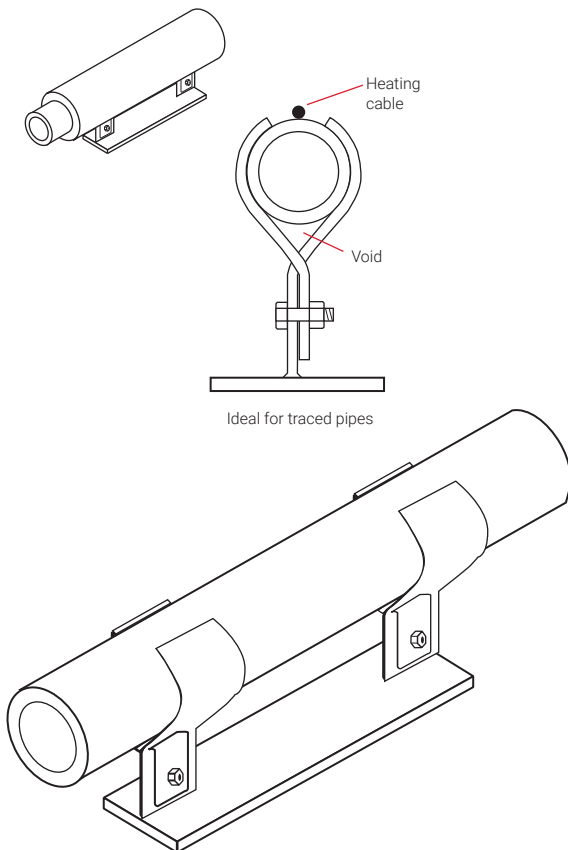

### PRODUCT OVERVIEW

The nVent RAYCHEM Interlock clamp-on pipe shoe is a patented pipe support designed to eliminate field welding requirements for pipe supports, while overcoming the many disadvantages associated with the clamp-on pipe shoes that are available on the market today.

The Interlock pipe shoe is more cost effective when compared to either conventional clamp-on pipe supports or field welded pipe supports and can be used on all pipe applications including bare pipe, painted pipe, insulated pipe, or heat-traced pipe.

Interlock pipe shoes may reduce the amount of heat loss at supports to a negligible level.

The Interlock pipe shoe is designed for use on nominal pipe sizes ranging from 1-in (25.4 mm) through 8-in (203.2 mm), and is available in heights of 3-in (76.2 mm), 4-in (101.6 mm), and 6-in (152.4 mm) to accommodate varying thicknesses of pipe insulation. The Interlock shoe is made from hot dip galvanized A-36 carbon steel for corrosion protection.

### BENEFITS

Reduced heat loss

The clamps of a conventional clamp-on pipe shoe extend radially outward from the pipe, increasing the labor and reducing the integrity of insulation local to the support. Interlock, with its unique cross section, offers reduced installation time and increased insulation integrity.

Increased pipe rack utilization

Because of its minimal profile, the Interlock shoe allows for better rack utilization by reducing the clearance required to accommodate the extended clamps of conventional shoes.

No pipe corrosion

Corrosion has historically been a major problem with conventional clamp-on shoes. Protective coatings tend to deteriorate between the support and the pipe bottom because of moisture or other trapped contaminants. Because the Interlock shoe does not have a saddle that will collect moisture or other corrosive media, the corrosion problem associated with conventional clamp-on pipe supports is not an issue.

Traced pipes

The Interlock shoe is the only clamp-on shoe that allows for direct contact between the heat tracing and the pipe. Heat tracing can be installed between the clamp tongs, allowing for maximum heat transfer. The minimal profile of the Interlock shoe reduces heat loss significantly more than other clamp-on shoes.

## OPERATING TEMPERATURES

Temperature

The standard Interlock shoe (made of A-36 carbon steel) can be used in services from -20°F (-28.9°C) to 400°F (204.4°C).

## DIMENSIONS

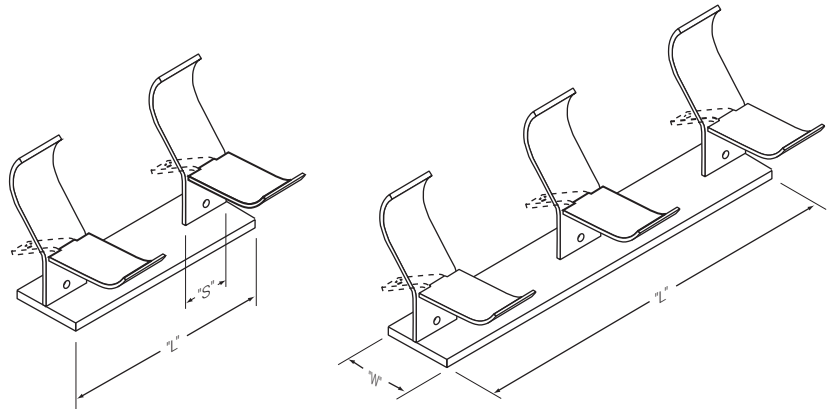
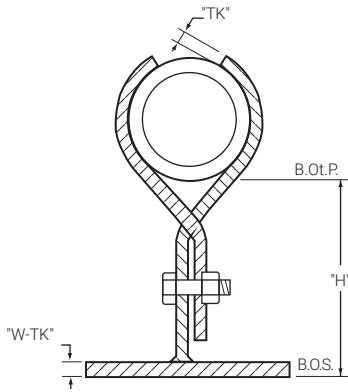

## MATERIALS OF CONSTRUCTION

Material

Interlock shoe is made out of A-36 carbon steel, but is also available in other materials of construction for special applications.

Base

Depending on the application, includes either two or three support tongs welded to the Interlock shoe. These support tongs have a lever gap stamped in their base through which a mating tong is inserted. When the mating tong is bolted to the support tong, the pipe ends of the tong are drawn together, gripping the pipe.

Assembly

The entire assembly is galvanized (6 mil thick) for corrosion protection.

## PRODUCT SPECIFICATIONS

Pipe size inch (mm)	L inch (mm)	H inch (mm)	W inch (mm)	S inch (mm)	W-TK inch (mm)	TK inch (mm)	Plate	Bolt/Nut
1 (25.4), 1.5 (38.1)	12 (304.8), 18 (457.2)	3 (76.2), 4 (101.6)	3 (76.2)	3 (76.2)	3/8 (9.525)	3/16 (4.762)	A-36	1/2" (12.7 mm)
2 (50.8)	12 (304.8), 18 (457.2)	6 (152.4)	4 (101.6)	3 (76.2)	3/8 (9.525)	3/16 (4.762)	C.S.	A449 w/2 H nut
3 (76.2), 4 (101.6)	12 (304.8), 18 (457.2)	3 (76.2), 4 (101.6)	3 (76.2)	3 (76.2)	3/8 (9.525)	1/4 (6.35)	A-36	1/2" (12.7 mm)
	12 (304.8), 18 (457.2)	6 (152.4)	6 (152.4)	3 (76.2)	3/8 (9.525)	1/4 (6.35)	C.S.	A449 w/2 H nut
6 (152.4)	12 (304.8), 18 (457.2)	3 (76.2), 4 (101.6)	4 (101.6)	4 (101.6)	3/8 (9.525)	1/4 (6.35)	A-36	1/2" (12.7 mm)
	12 (304.8), 18 (457.2)	6 (152.4)	6 (152.4)	4 (101.6)	3/8 (9.525)	1/4 (6.35)	C.S.	A449 w/2 H nut
8 (203.2)	12 (304.8), 18 (457.2)	3 (76.2), 4 (101.6)	4 (101.6)	4 (101.6)	3/8 (9.525)	5/16 (7.938)	A-36	1/2" (12.7 mm)
	12 (304.8), 18 (457.2)	6 (152.4)	6 (152.4)	4 (101.6)	3/8 (9.525)	5/16 (7.938)	C.S.	A449 w/2 H nut

## INTERLOCK ORDERING MATRIX: A / B / C / D

### Example

A = Pipe size – 1" (25.4 mm), 1.5" (38.1 mm), 2" (50.8 mm), 3" (76.2 mm), 4" (101.6 mm), 6" (152.4 mm), 8" (203.2 mm)

B = Shoe height – 3" (76.2 mm), 4" (101.6 mm), 6" (152.4 mm)

C = Shoe length – 12" (304.8 mm), 18" (457.2 mm)

D = Isolation/heat trace thermal boot – n/a, B

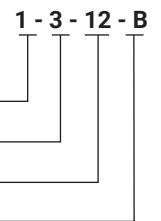

## ORDERING INFORMATION

### 2 Clamp – 12 inch (304.8 mm) Long Support

Nominal pipe size – inch (mm)		Height – inch (mm)		Catalog number	Weight – lbs (kg)	
1	(25.4)	3	(76.2)	1-3-12	6.50	(2.948)
1	(25.4)	4	(101.6)	1-4-12	7.00	(3.175)
1	(25.4)	6	(152.4)	1-6-12	9.75	(4.423)
1.5	(38.1)	3	(76.2)	1.5-3-12	7.00	(3.175)
1.5	(38.1)	4	(101.6)	1.5-4-12	7.50	(3.402)
1.5	(38.1)	6	(152.4)	1.5-6-12	10.50	(4.763)
2	(50.8)	3	(76.2)	2-3-12	7.25	(3.289)
2	(50.8)	4	(101.6)	2-4-12	7.75	(3.515)
2	(50.8)	6	(152.4)	2-6-12	10.75	(4.876)
3	(76.2)	3	(76.2)	3-3-12	8.25	(3.742)
3	(76.2)	4	(101.6)	3-4-12	8.50	(3.856)
3	(76.2)	6	(152.4)	3-6-12	13.25	(6.01)
4	(101.6)	3	(76.2)	4-3-12	11.25	(5.103)
4	(101.6)	4	(101.6)	4-4-12	11.50	(5.216)
4	(101.6)	6	(152.4)	4-6-12	17.25	(7.824)
6	(152.4)	3	(76.2)	6-3-12	16.75	(7.598)
6	(152.4)	4	(101.6)	6-4-12	17.00	(7.711)
6	(152.4)	6	(152.4)	6-6-12	22.50	(10.21)
8	(203.2)	3	(76.2)	8-3-12	22.00	(9.979)
8	(203.2)	4	(101.6)	8-4-12	23.50	(10.66)
8	(203.2)	6	(152.4)	8-6-12	29.50	(13.38)
Isolation insert for 12"				-B	–	

### 3 Clamp – 18 inch (457.2 mm) Long Support

Nominal pipe size – inch (mm)		Height – inch (mm)		Catalog number	Weight – lbs (kg)	
1	(25.4)	3	(76.2)	1-3-18	9.75	(4.423)
1	(25.4)	4	(101.6)	1-4-18	10.50	(4.763)
1	(25.4)	6	(152.4)	1-6-18	14.75	(6.69)
1.5	(38.1)	3	(76.2)	1.5-3-18	10.50	(4.763)
1.5	(38.1)	4	(101.6)	1.5-4-18	11.25	(5.103)
1.5	(38.1)	6	(152.4)	1.5-6-18	15.75	(7.144)
2	(50.8)	3	(76.2)	2-3-18	10.88	(4.935)
2	(50.8)	4	(101.6)	2-4-18	11.75	(5.33)
2	(50.8)	6	(152.4)	2-6-18	16.00	(7.257)
3	(76.2)	3	(76.2)	3-3-18	12.50	(5.67)
3	(76.2)	4	(101.6)	3-4-18	12.75	(5.783)
3	(76.2)	6	(152.4)	3-6-18	20.00	(9.072)
4	(101.6)	3	(76.2)	4-3-18	17.00	(7.711)
4	(101.6)	4	(101.6)	4-4-18	17.25	(7.824)
4	(101.6)	6	(152.4)	4-6-18	26.00	(11.79)
6	(152.4)	3	(76.2)	6-3-18	25.00	(11.34)
6	(152.4)	4	(101.6)	6-4-18	25.50	(11.57)
6	(152.4)	6	(152.4)	6-6-18	33.75	(15.31)
8	(203.2)	3	(76.2)	8-3-18	33.00	(14.97)
8	(203.2)	4	(101.6)	8-4-18	35.25	(15.99)
8	(203.2)	6	(152.4)	8-6-18	44.25	(20.07)
Isolation insert for 18" (457.2 mm)				-B	–	

**North America**

Tel +1.800.545.6258  
Fax +1.800.527.5703  
thermal.info@nvent.com

**Europe, Middle East, Africa**

Tel +32.16.213.511  
Fax +32.16.213.604  
thermal.info@nvent.com

**Asia Pacific**

Tel +86.21.2412.1688  
Fax +86.21.5426.3167  
cn.thermal.info@nvent.com

**Latin America**

Tel +1.713.868.4800  
Fax +1.713.868.2333  
thermal.info@nvent.com



[nVent.com](http://nVent.com)

Our powerful portfolio of brands:

**CADDY ERICO HOFFMAN RAYCHEM SCHROFF TRACER**